

THE CONNECTING BETWEEN TOYOTA VEHICLES ARE NOT OBD-II AND EFI SCAN

A. LOCATION OF CONNECTOR & ECU



B. CONNECTION IN THE DIAGNOSE ENGINE SYSTEM

1. Case of DLC1

1.1. Case of W pin is available on the connector

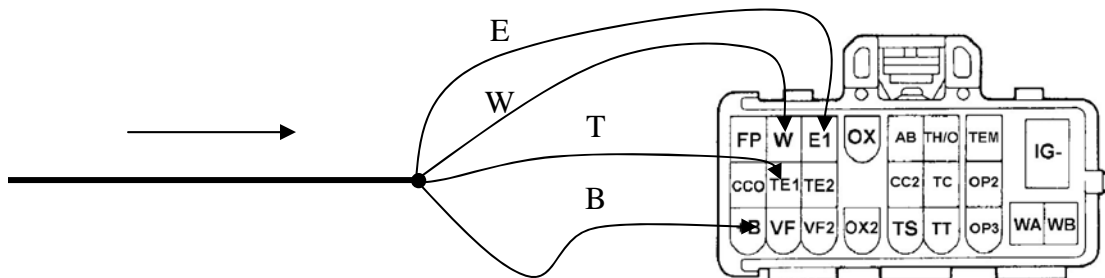

1.2. Case of W pin is not available on the connector

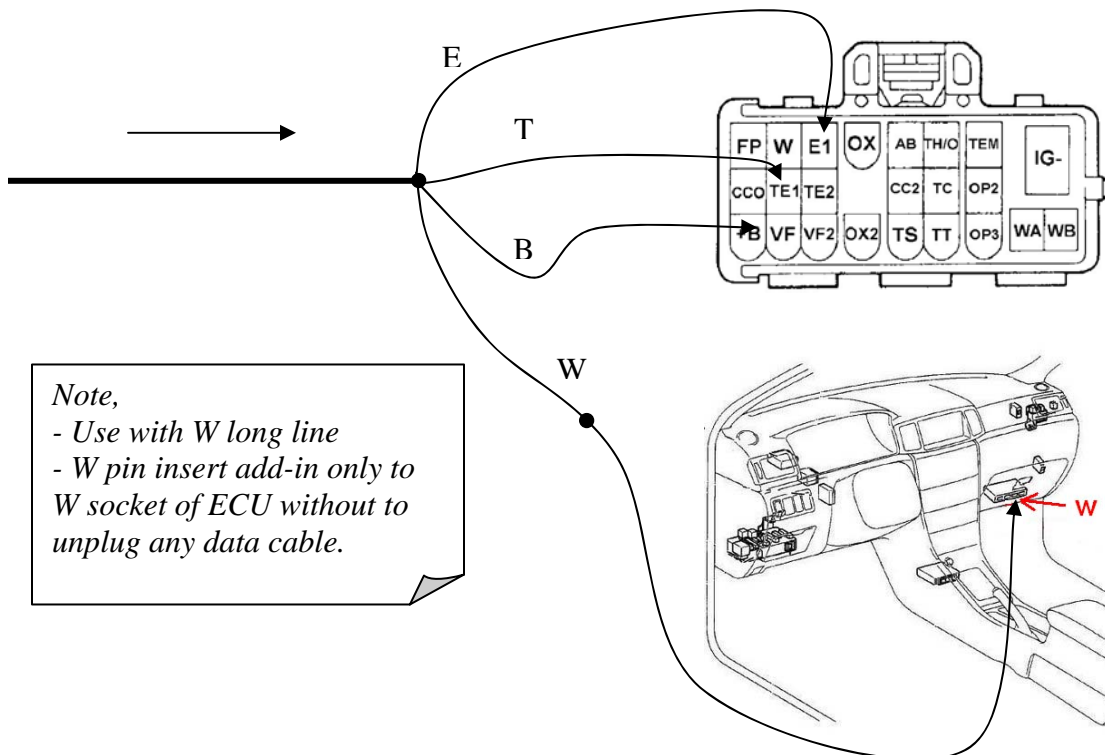

Note,

- Use with W long line
- W pin insert add-in only to W socket of ECU without to unplug any data cable.

2. Case of both DLC1 & DLC2

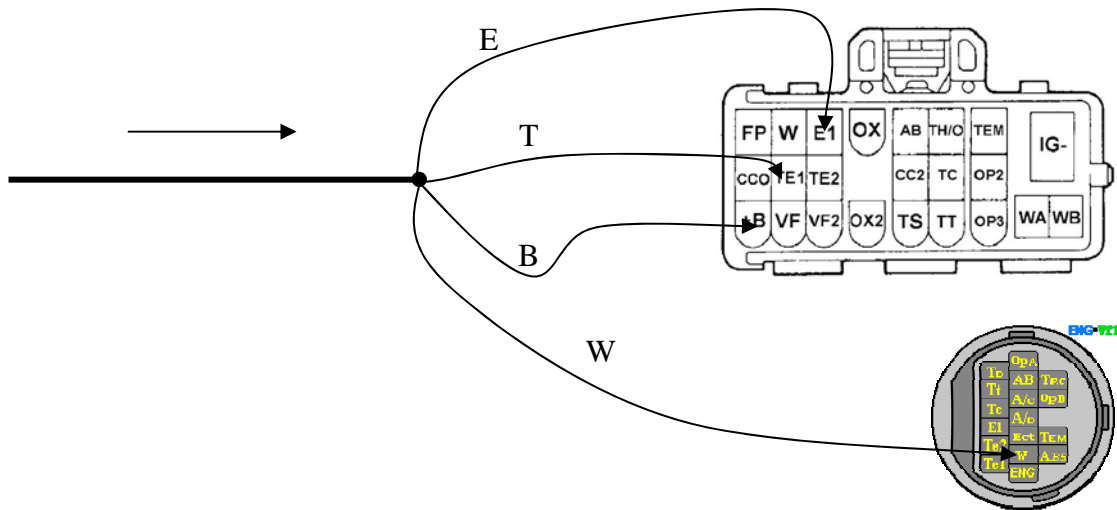

3. Case of DLC3 (16 pins look like OBD-II but pin 13 is available)

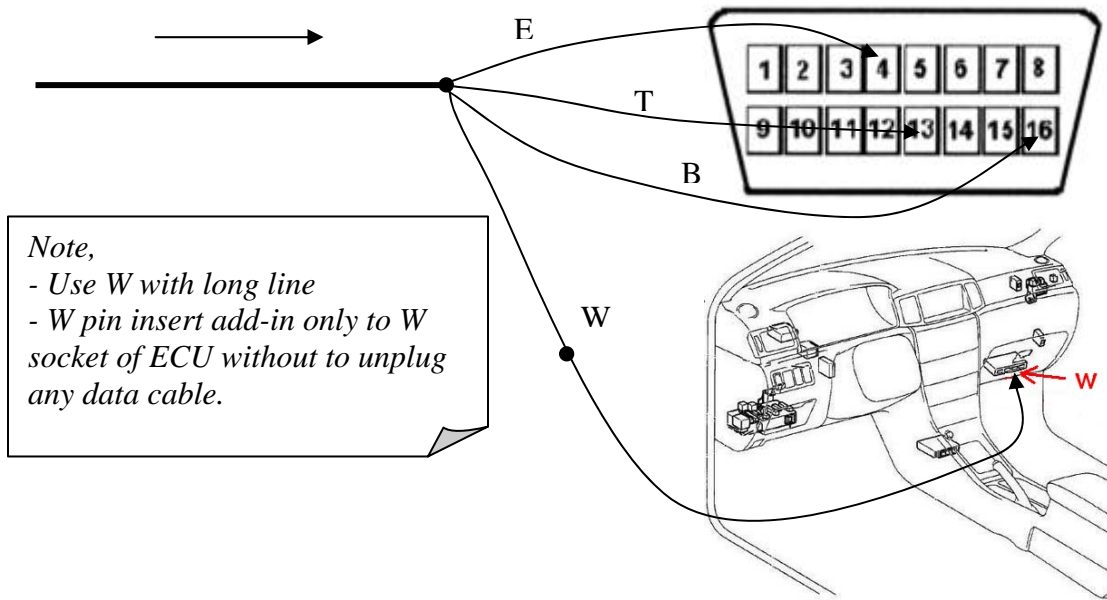

C. CONNECTION IN THE DIAGNOSE ABS SYSTEM

1. Case of DLC1

→ *Note, you must remove jumper of Wa-Wb*

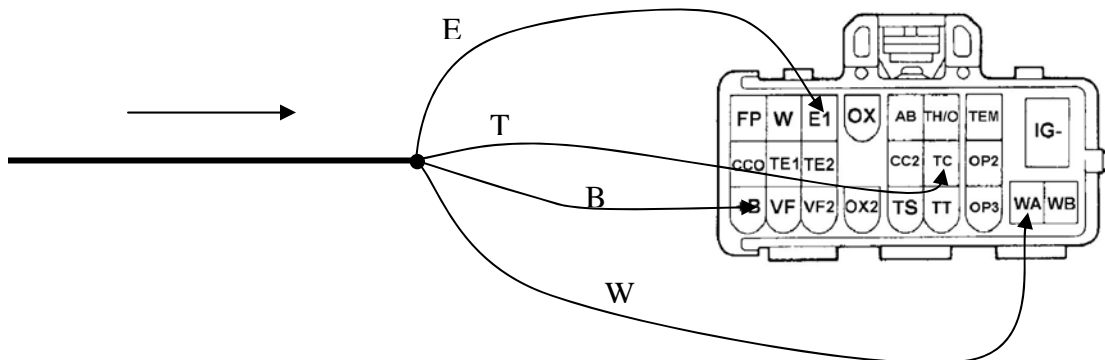

2. Case of DLC3

